

(12) UK Patent

(19) GB

(11) 2528959

(13) C

(45) Date of B Publication

08.02.2017

(54) Title of the Invention: **Encoder, decoder and methods**

(51) INT CL: **H04L 9/18** (2006.01)

(21) Application No: **1414007.3**

(22) Date of Filing: **07.08.2014**

(43) Date of A Publication: **10.02.2016**

(56) Documents Cited:  
**US 8660261 B2**                      **US 20060188095 A1**

(58) Field of Search:  
As for published application 2528959 A viz:  
INT CL **G06F, H04L**  
Other: **WPI, EPODOC, INSPEC and the Internet**  
updated as appropriate

(72) Inventor(s):  
**Tuomas Mikael Kärkkäinen**

(73) Proprietor(s):  
**Gurulogic Microsystems Oy**  
**Linnankatu 34, Turku 20100, Finland**

(74) Agent and/or Address for Service:  
**Basck Ltd**  
**16 Saxon Road, CAMBRIDGE, Cambridgeshire,**  
**CB5 8HS, United Kingdom**

GB 2528959 C

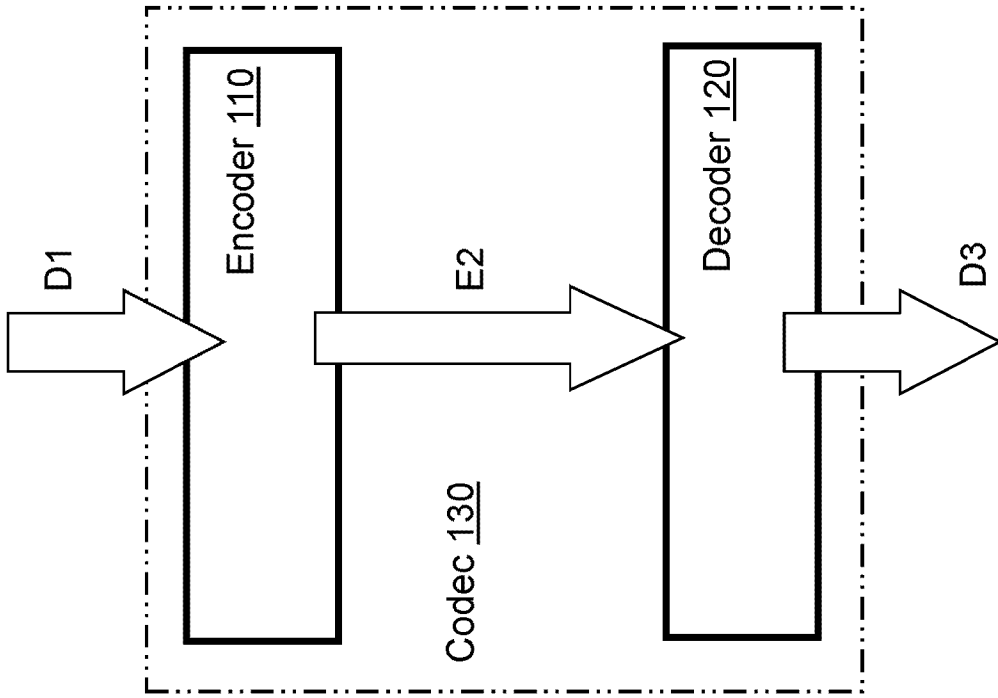

FIG. 1

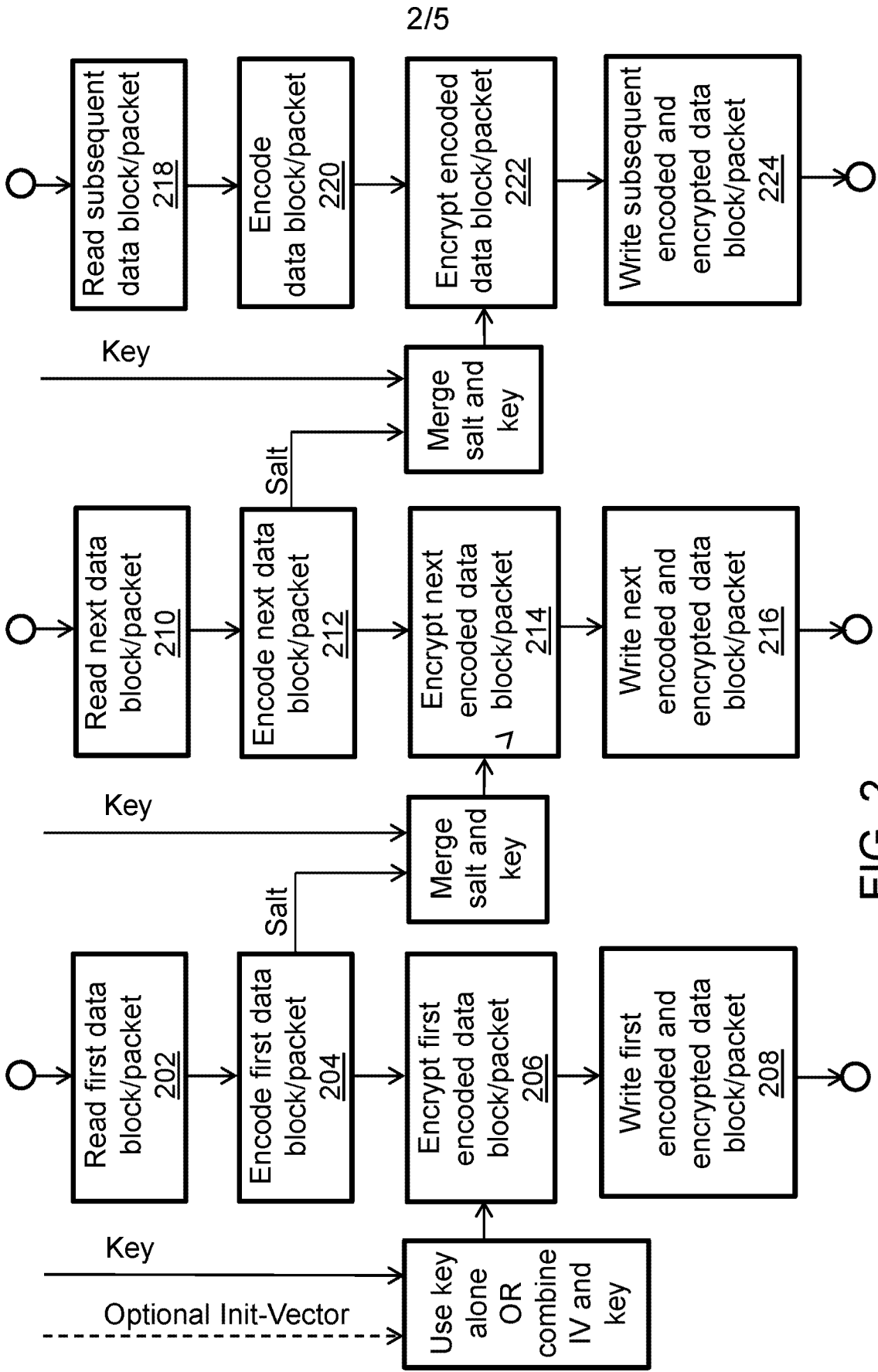

FIG. 2

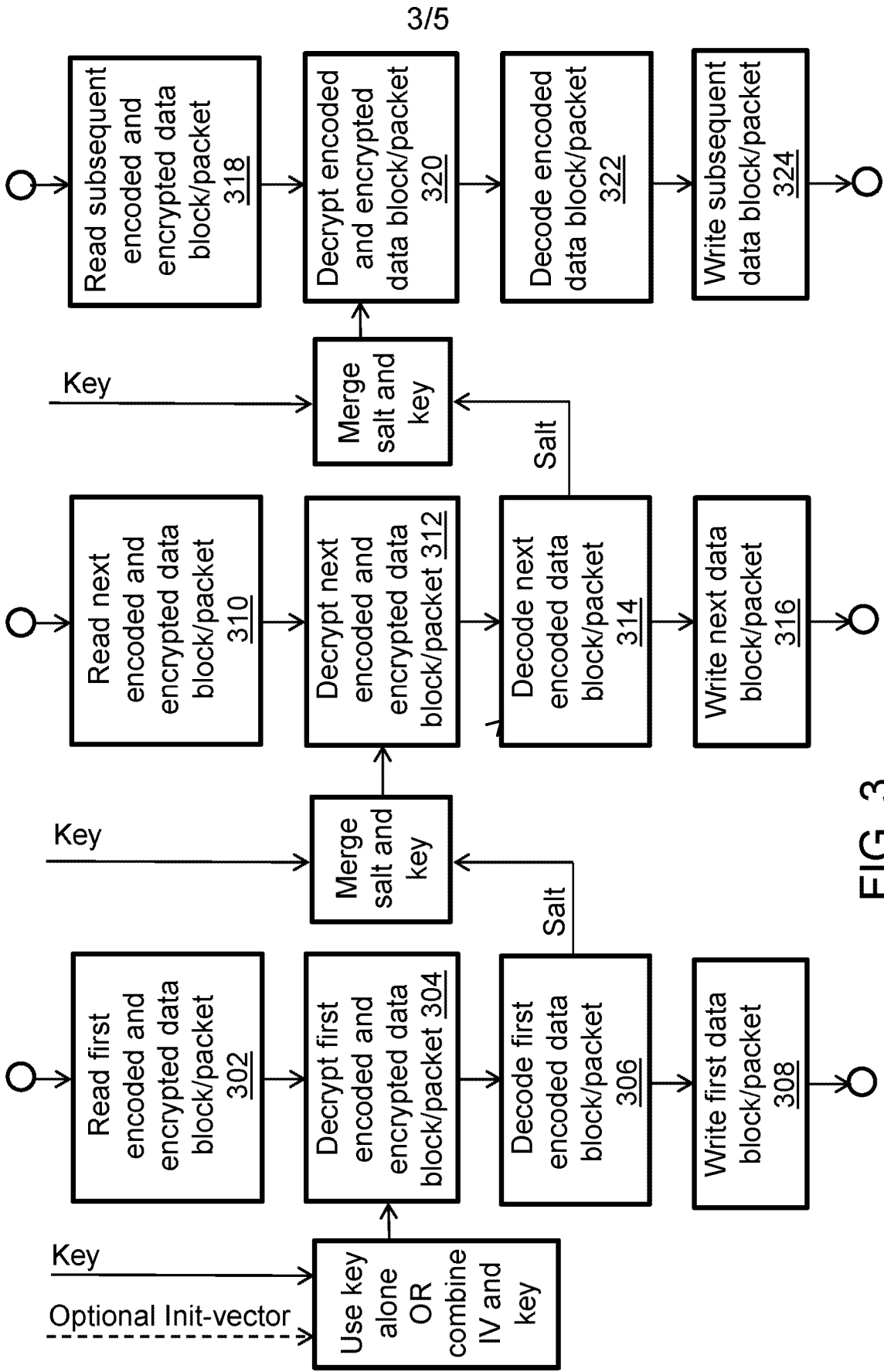

FIG. 3

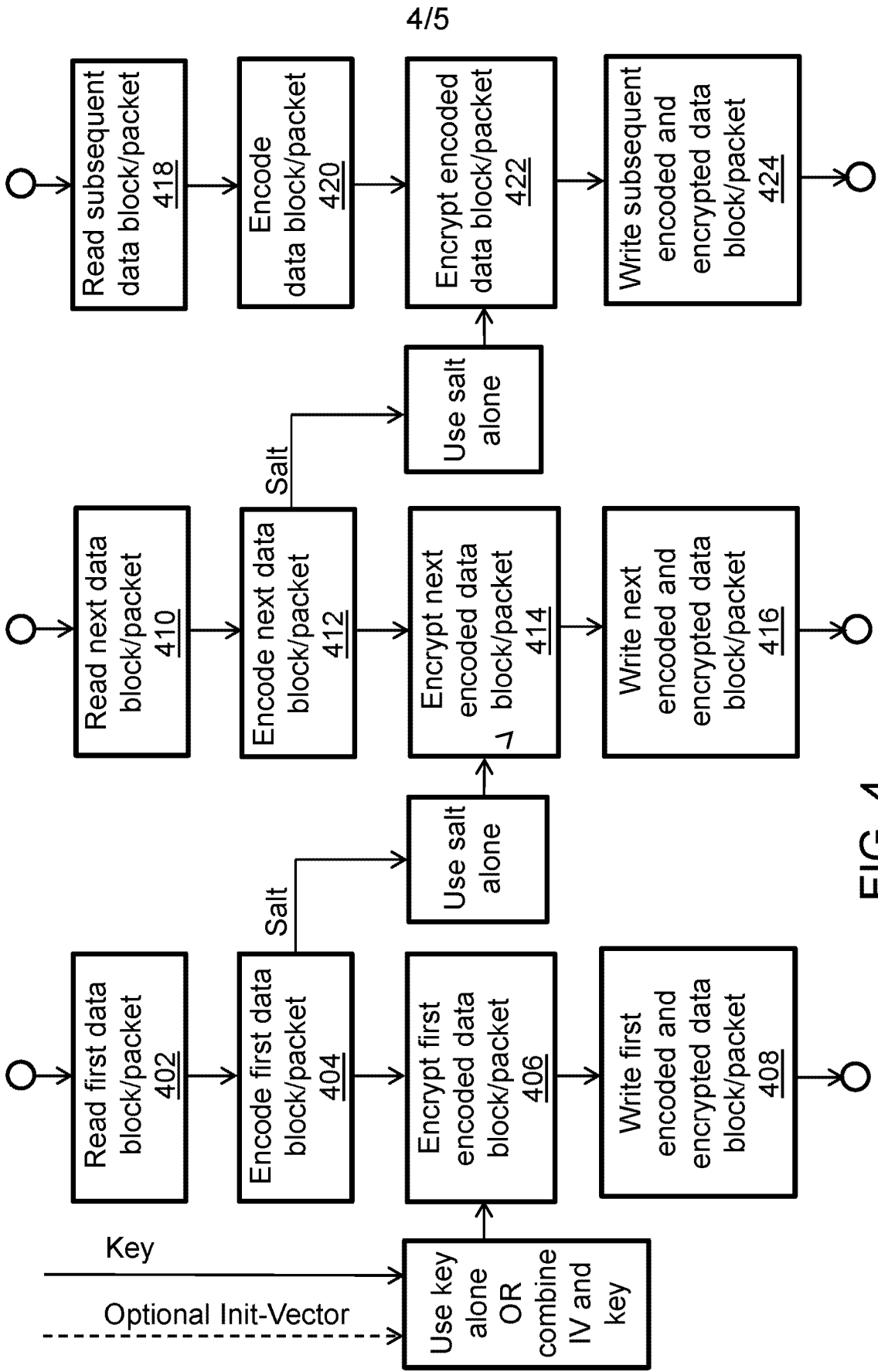

FIG. 4

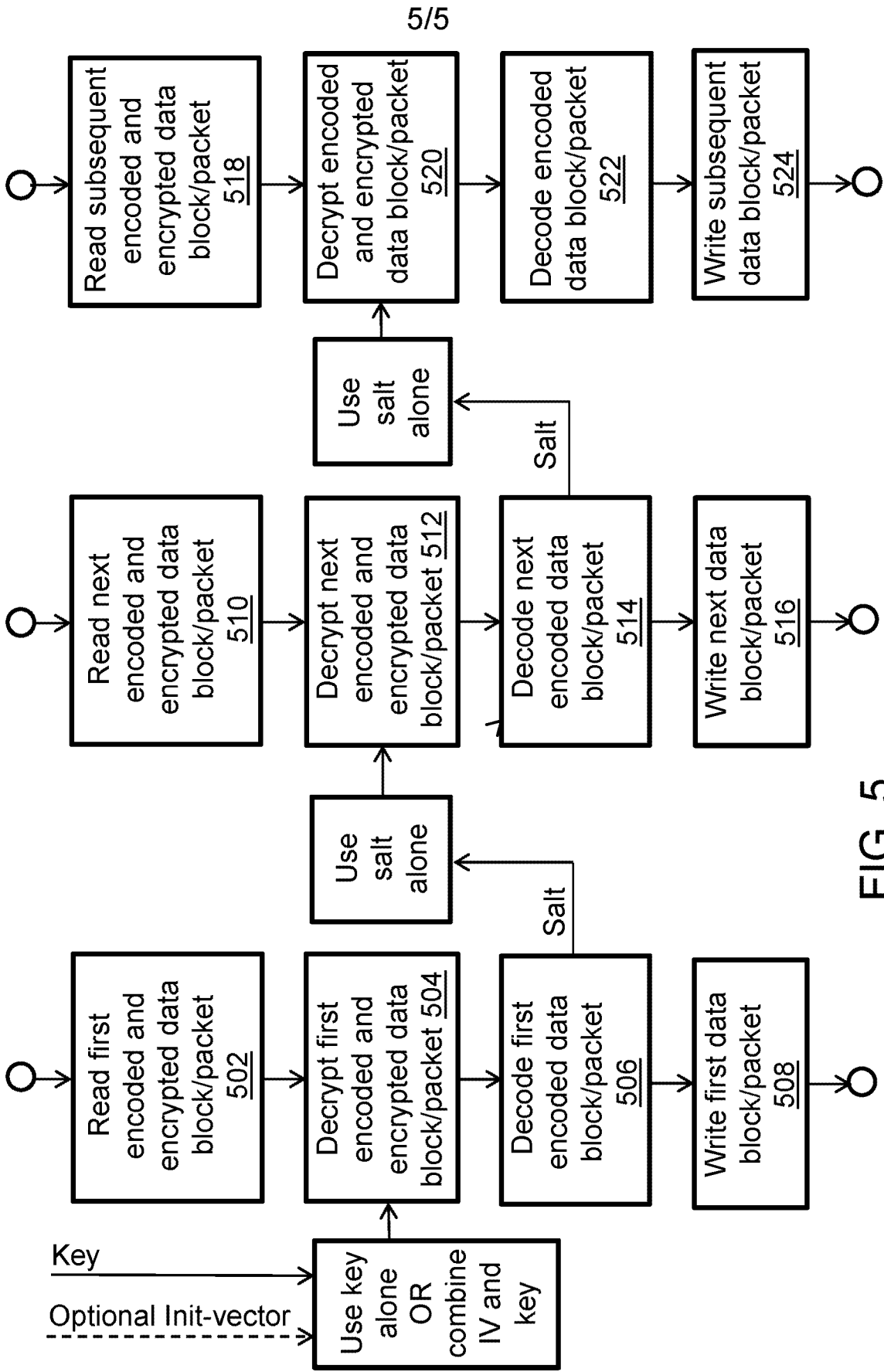

FIG. 5

## ENCODER, DECODER AND METHODS

### TECHNICAL FIELD

5 The present disclosure relates to encoders for encoding and encrypting input data (D1) to generate corresponding encoded and encrypted data (E2), and corresponding methods of encoding and encrypting input data (D1) to generate corresponding encoded and encrypted data (E2). Moreover, the present disclosure relates to decoders for decrypting and decoding encoded and encrypted data (E2) to generate corresponding decoded data (D3), and corresponding methods of  
10 decrypting and decoding encoded and encrypted data (E2) to generate corresponding decoded data (D3). Furthermore, the present disclosure is concerned with computer program products comprising a non-transitory computer-readable storage medium having computer-readable instructions stored thereon, the computer-readable instructions being executable by a computerized device comprising processing hardware to execute aforesaid methods. Additionally, the present disclosure concerns codecs including at least one aforementioned encoder and at least one aforementioned decoder.

### BACKGROUND

15 In general, the term "*encryption*" refers to a process of encoding messages or information in such a way that only authorized parties can read the messages or information. A field of science that deals with encryption is called cryptography. Information has been encrypted throughout history, and it is well known that each encryption algorithm has its own associated weaknesses. Cryptanalysis, which is a branch of cryptology, is used to find weaknesses in encryption algorithms.

25 Encryption algorithms can be categorized into symmetric algorithms (namely, symmetric-key algorithms) and asymmetric algorithms (namely, asymmetric-key algorithms). The symmetric and asymmetric algorithms mutually differ in a way in which an encryption key is used and processed. Symmetric encryption algorithms  
30 use a shared common key to encrypt data at a transmitting end and to decrypt encrypted data at a corresponding receiving end. On the other hand, asymmetric

09 10 15

encryption algorithms use two different keys, one of which is a public key used to encrypt data and the other is a private key used to decrypt encrypted data. Only the public key is shared between parties.

5 Moreover, there are one-way message digest functions, namely hash functions, which are not data encryption techniques as such, because data they represent are difficult or impossible to recover. However, one-way message digest functions are used to verify an authenticity of data and passwords, and also are used to generate encryption keys for encryption algorithms.

10

It is well-known that data encryption is a technically demanding operation that requires a lot of computing resources. Therefore, in order to save on computing resources and to reduce computing time, a hybrid combination of asymmetric and symmetric encryption algorithms is often used. This provides a sufficiently strong protection, such that unauthorized third-party decryption cannot be executed in real time with current computing resources. Such a kind of approach is commonly used in various different data transfer protocols, for example, such as Secure Sockets Layer (SSL)/Transport Layer Security (TLS) and Secure Shell (SSH), and in applications to sign and encrypt e-mail messages, for example, such as Pretty Good Privacy (PGP).

15

20

It has been established that cryptology, namely the scientific study of cryptography and cryptanalysis, is a continuously developing field of science that, with means of cryptanalysis, attempts to find weaknesses in encryption algorithms. For this reason, it is essential to be able to protect information maximally, but correspondingly there is a need to make compromises regarding use of computing resources used to implement the encryption. Moreover, the computing resources available are usually limited, especially in mobile devices which do their utmost to save battery power.

25

30

In a United States patent document US2006/0188095A1 (Jung *et al.*; "*Combination encoding method for simultaneous encrypting and channel encoding, transmitting apparatus thereof, combination decoding method for simultaneous channel decoding and decrypting, and receiving apparatus thereof*"; assigned to Samsung Electronics Co. Ltd.), there is described a combination encoding method, a transmitting apparatus thereof, a combination decoding method, and a receiving apparatus

09 10 15



thereof. The transmitting apparatus includes a combination encoding unit for performing combination encoding on a source coded message and outputting the combination encoded message, thereby performing encrypting and channel encoding simultaneously. The receiving apparatus includes a combination decoding unit for performing combination decoding on a noise-added combination encoded message from a demodulator, and outputting a source coded message, thereby simultaneously performing channel decoding and decrypting on the noise-added combination encoded message.

In a United States patent document US 8660261B2 (Chang *et al.*; “*System and apparatus for integrated video/image encoding/decoding and encryption/decryption*”, assigned to Mediatek Singapore Pte. Ltd.), there is described an encryption-enabled entropy coder for a multimedia codec. The entropy coder implements a randomized Huffman coding scheme without storing multiple sets of Huffman tables in a read-only memory (ROM). The entropy coder includes a ROM storing a single set of code tables, a table lookup section coupled to the ROM which converts symbols to original code-words and *vice versa* by performing table lookup, and a table randomizer section for converting original Huffman code-words to randomized Huffman codewords and *vice versa*, using an isomorphic code generator algorithm. The table randomizer section performs the conversion based upon a key hopping sequence generated by a pseudorandom bit generator using an encryption/decryption key.

## SUMMARY

The present disclosure seeks to provide an encoder for encoding and encrypting input data (D1) to generate corresponding encoded and encrypted data (E2).

Moreover, the present disclosure seeks to provide a decoder for decrypting and decoding encoded and encrypted data (E2) to generate corresponding decoded data (D3).

In a first aspect, embodiments of the present disclosure provide an encoder for encoding and encrypting input data (D1) including a plurality of data blocks and/or

09 10 15  
20

5

10

15

20

25

30

data packets, wherein the encoder includes a data processing arrangement for processing the input data (D1) to generate corresponding encoded and encrypted data (E2), characterized in that:

- 5 (i) the data processing arrangement is operable to encode at least a first data block and/or data packet of the plurality of data blocks and/or data packets to generate a first encoded data block and/or data packet, and to encrypt the at least a first encoded data block and/or data packet using at least one key to provide a first encoded and encrypted data block and/or data packet for  
10 inclusion in the encoded and encrypted data (E2);
- (ii) the data processing arrangement is operable to generate a first seed value for use in encrypting a next encoded data block and/or data packet to provide a next encoded and encrypted data block and/or data packet for inclusion in the encoded and encrypted data (E2); and
- 15 (iii) the data processing arrangement is operable to generate a next seed value for use in encrypting a subsequent encoded data block and/or data packet, in a sequential repetitive manner until the plurality of data blocks and/or data packets are encoded and encrypted into the encoded and encrypted data (E2).

20 The data processing arrangement of the encoder is operable to encode at least a first data block and/or data packet of the plurality of data blocks and/or data packets to generate a first encoded data block and/or data packet. The data processing arrangement of the encoder is then operable to encrypt the at least a first encoded  
25 data block and/or data packet using the at least one key to provide a first encoded and encrypted data block and/or data packet for inclusion in the encoded and encrypted data (E2).

30 Moreover, the data processing arrangement of the encoder is operable to generate a first seed value for use in encrypting a next encoded data block and/or data packet to provide a next encoded and encrypted data block and/or data packet for inclusion in the encoded and encrypted data (E2). Subsequently, the data processing arrangement of the encoder is operable to generate a next seed value for use in encrypting a subsequent encoded data block and/or data packet, in a sequential

09 10 15  
20

repetitive manner until the plurality of data blocks and/or data packets are encoded and encrypted into the encoded and encrypted data (E2).

Moreover, optionally, the data processing arrangement of the encoder is operable to encode and encrypt the input data (D1) to generate the corresponding encoded and encrypted data (E2) in the sequential repetitive manner by branching to a plurality of concurrent sequences of encoding and encrypting of data blocks and/or data packets using associated seed values.

Optionally, the data processing arrangement of the encoder is implemented by employing at least one Reduced Instruction Set Computing (RISC) processor that is operable to execute program instructions as will be elucidated in detail below.

Optionally, the data processing arrangement of the encoder is operable to encode and encrypt the input data (D1) provided in a form of at least one of: one-dimensional data, multi-dimensional data, text data, binary data, sensor data, audio data, image data, video data, but not limited thereto.

Optionally, the data processing arrangement of the encoder is supplied in operation with at least one key for use in generating the encoded and encrypted data (E2).

Optionally, the data processing arrangement of the encoder is operable to use the at least one key repetitively in combination with the seed values for encrypting encoded data blocks and/or data packets for inclusion in the encoded and encrypted data (E2). Alternatively, optionally, the data processing arrangement of the encoder is operable to use the at least one key only for encrypting the first encoded data block and/or data packet.

Moreover, optionally, the data processing arrangement of the encoder is operable to employ an initialization vector (IV) in combination with the at least one key for encrypting the first encoded data block and/or data packet.

Moreover, optionally, the data processing arrangement of the encoder is operable to include in the encoded and encrypted data (E2) information indicative of at least one

09 10 15  
20

5

10

15

20

25

30

algorithm employed for generating the seed values for use in encrypting the encoded data blocks and/or data packets.

Moreover, optionally, the data processing arrangement of the encoder is operable to  
5 arrange for delivery of the at least one key, for use in subsequent decrypting and decoding of the encoded and encrypted data (E2), manually or via an encrypted e-mail or via an encrypted communication connection. Optionally, the encrypted communication connection is implemented via Secure Sockets Layer (SSL)/Transport Layer Security (TLS) protocol.

10 In a second aspect, embodiments of the present disclosure provide a method of encoding and encrypting input data (D1) including a plurality of data blocks and/or data packets, via an encoder, wherein the encoder includes a data processing arrangement for processing the input data (D1) to generate corresponding encoded and encrypted data (E2), characterized in that the method includes:

- 15
- (i) encoding a first data block and/or data packet of the plurality of data blocks and/or data packets to generate at least a first encoded data block and/or data packet;
  - (ii) encrypting the at least a first encoded data block and/or data packet using at least one key to provide a first encoded and encrypted data block and/or data packet for inclusion in the encoded and encrypted data (E2);
  - (iii) generating a first seed value for use in encrypting a next encoded data block and/or data packet to provide a next encoded and encrypted data block and/or data packet for inclusion in the encoded and encrypted data (E2); and
  - 25 (iv) generating a next seed value for use in encrypting a subsequent encoded data block and/or data packet, in a sequential repetitive manner until the plurality of data blocks and/or data packets are encoded and encrypted into the encoded and encrypted data (E2).

30 In a third aspect, embodiments of the present disclosure provide a computer program product comprising a non-transitory (namely non-transient) computer-readable storage medium having computer-readable instructions stored thereon, the computer-readable instructions being executable by a computerized device comprising processing hardware to execute the aforementioned method.

09 10 15  
20

In a fourth aspect, embodiments of the present disclosure provide a decoder for decrypting and decoding encoded and encrypted data (E2) including a plurality of encoded and encrypted data blocks and/or data packets, wherein the decoder includes a data processing arrangement for processing the encoded and encrypted data (E2) to generate corresponding decoded data (D3), and wherein the decoder is supplied in operation with at least one key for use in generating the decoded data (D3), characterized in that:

- 10 (i) the data processing arrangement is operable to decrypt at least a first encoded and encrypted data block and/or data packet of the plurality of encoded and encrypted data blocks and/or data packets using the at least one key to generate at least a first encoded data block and/or data packet, and to decode the at least first encoded data block and/or data packet to provide at least a first decoded data block and/or data packet for inclusion in the decoded data (D3);
- 15 (ii) the data processing arrangement is operable to generate a first seed value for use in decrypting a next encoded and encrypted data block and/or data packet of the plurality of encoded and encrypted data blocks and/or data packets to generate a next encoded data block and/or data packet, and to decode the next encoded data block and/or data packet to provide a next decoded data block and/or data packet for inclusion in the decoded data (D3); and
- 20 (iii) the data processing arrangement is operable to generate a next seed value for use in decrypting and decoding a subsequent encoded and encrypted data block and/or data packet of the plurality of encoded and encrypted data blocks and/or data packets, in a sequential repetitive manner until the plurality of encoded and encrypted data blocks and/or data packets are decrypted and decoded into the decoded data (D3).

25  
30 Optionally, the data processing arrangement of the decoder is operable to decrypt and decode the encoded and encrypted data (E2) provided in a form of at least one of: encoded and encrypted one-dimensional data, encoded and encrypted multi-dimensional data, encoded and encrypted text data, encoded and encrypted binary data, encoded and encrypted sensor data, encoded and encrypted audio data,

09 10 15  
20

encoded and encrypted image data, encoded and encrypted video data, but not limited thereto.

Optionally, the data processing arrangement of the decoder is supplied in operation  
5 with the at least one key for use in generating the decoded data (D3).

The data processing arrangement of the decoder is operable to decrypt a first  
encoded and encrypted data block and/or data packet of the plurality of encoded and  
encrypted data blocks and/or data packets using the at least one key to generate a  
10 first encoded data block and/or data packet. The data processing arrangement of the  
decoder is then operable to decode the first encoded data block and/or data packet  
to provide a first decoded data block and/or data packet for inclusion in the decoded  
data (D3).

09 10 15  
20 15 The data processing arrangement of the decoder is operable to generate a first seed  
value for use in decrypting a next encoded and encrypted data block and/or data  
packet of the plurality of encoded and encrypted data blocks and/or data packets to  
generate a next encoded data block and/or data packet. The data processing  
arrangement of the decoder is then operable to decode the next encoded data block  
and/or data packet to provide a next decoded data block and/or data packet for  
inclusion in the decoded data (D3).

Subsequently, the data processing arrangement of the decoder is operable to  
generate a next seed value for use in decrypting and decoding a subsequent  
25 encoded and encrypted data block and/or data packet of the plurality of encoded and  
encrypted data blocks and/or data packets, in a sequential repetitive manner until the  
plurality of encoded and encrypted data blocks and/or data packets of the encoded  
and encrypted data (E2) are decrypted and decoded into the decoded data (D3).

30 Moreover, optionally, the data processing arrangement of the decoder is operable to  
decrypt and decode the encoded and encrypted data (E2) to generate the  
corresponding decoded data (D3) in the sequential repetitive manner by branching to  
a plurality of concurrent sequences of decrypting and decoding of encoded and  
encrypted data blocks and/or data packets using associated seed values.

Optionally, the data processing arrangement of the decoder is implemented by employing at least one RISC processor that is operable to execute program instructions as will be elucidated in detail later; such a RISC processor is capable of performing relatively simpler concatenated operations at very great speed, and suitable for encoding and decoding data provided in a streamed format, for example in real-time.

Optionally, the data processing arrangement of the decoder is operable to decrypt and decode the encoded and encrypted data (E2) provided in a form of at least one of: encoded and encrypted one-dimensional data, encoded and encrypted multi-dimensional data, encoded and encrypted text data, encoded and encrypted binary data, encoded and encrypted sensor data, encoded and encrypted audio data, encoded and encrypted image data, encoded and encrypted video data, but not limited thereto.

Optionally, the data processing arrangement of the decoder is supplied in operation with the at least one key for use in generating the decoded data (D3).

Optionally, the data processing arrangement of the decoder is operable to use the at least one key repetitively in combination with the seed values for decrypting the encoded and encrypted data blocks and/or data packets of the encoded and encrypted data (E2). Alternatively, optionally, the data processing arrangement of the decoder is operable to use the at least one key only for decrypting the first encoded and encrypted data block and/or data packet.

Moreover, optionally, the data processing arrangement of the decoder is operable to employ an initialization vector (IV) in combination with the at least one key for decrypting the first encoded and encrypted data block and/or data packet.

In a fifth aspect, embodiments of the present disclosure provide a method of decrypting and decoding encoded and encrypted data (E2) including a plurality of encoded and encrypted data blocks and/or data packets, via a decoder, wherein the decoder includes a data processing arrangement for processing the encoded and

09 10 15

5

10

15

20

25

30

encrypted data (E2) to generate corresponding decoded data (D3), and wherein the decoder is supplied in operation with at least one key for use in generating the decoded data (D3), characterized in that the method includes:

- (i) decrypting at least a first encoded and encrypted data block and/or data packet of the plurality of encoded and encrypted data blocks and/or data packets using the at least one key to generate at least a first encoded data block and/or data packet;
- (ii) decoding the at least first encoded data block and/or data packet to provide at least a first decoded data block and/or data packet for inclusion in the decoded data (D3);
- (iii) generating a first seed value for use in decrypting and decoding a next encoded and encrypted data block and/or data packet of the plurality of encoded and encrypted data blocks and/or data packets to provide a next decoded data block and/or data packet for inclusion in the decoded data (D3); and
- (iv) generating a next seed value for use in decrypting and decoding a subsequent encoded and encrypted data block and/or data packet of the plurality of encoded and encrypted data blocks and/or data packets, in a sequential repetitive manner until the plurality of encoded and encrypted data blocks and/or data packets are decrypted and decoded into the decoded data (D3).

In a sixth aspect, embodiments of the present disclosure provide a computer program product comprising a non-transitory (namely non-transient) computer-readable storage medium having computer-readable instructions stored thereon, the computer-readable instructions being executable by a computerized device comprising processing hardware to execute the aforementioned method.

In a seventh aspect, embodiments of the present disclosure provide a codec including the aforementioned encoder and the aforementioned decoder.

The aforementioned methods facilitate a considerable protection improvement as compared with protection achieved with prior art methods using corresponding encryption algorithms. The methods pursuant to embodiments of the present disclosure can be implemented with any suitable encoding solution, irrespective of

09 10 15  
20

5

10

15

20

25

30



which encryption algorithm is used. In doing so, these methods do not alter a behavior of an integrated encryption algorithm, which means that the protection provided by the integrated encryption algorithm is not compromised. Thus, the methods pursuant to embodiments of the present disclosure strengthen further the prior art data compression and encryption algorithms.

Moreover, the aforementioned methods can be implemented in connection with common, well-known open source or proprietary data compression software applications, such as 7-Zip or Win-Zip, and so forth (“7-Zip” and “Win-Zip” are proprietary trademarks).

Moreover, integration of encoding and encrypting processes offers an efficient model for multiprocessing, or running several processes in a parallel manner. The integration enables implementation of an optimal processing structure for a given Central Processing Unit (CPU) and a given Graphical Processing Unit (GPU) according to an available computing capacity. Thus, the aforementioned methods enable efficient threading of the integrated encryption process in the encoding process, when data blocks and/or data packets of the input data (D1) are optimized to a format that is optimal for the CPU and the GPU of a system and/or platform in which the encoding process is being run.

The aforementioned methods make it possible to use a very fast, yet efficient encryption algorithm. In this regard, the aforementioned methods use an encryption algorithm efficiently, without interfering with an inner operation of the encryption algorithm itself. Examples of encryption algorithms that are suitable for implementation with the aforementioned methods include, but are not limited to, AES, Twofish, Blowfish, Data Encryption Standard (DES), Triple DES (3-DES), Serpent, International Data Encryption Algorithm (IDEA), MARS, Rivest Cipher 6 (RC6), Camellia, CAST-128, Skipjack, eXtended Tiny Encryption Algorithm (XTEA), and so forth (these example names include registered trademarks).

Moreover, an additional advantage of integrating the encryption process with the encoding process is that the encoded and encrypted data (E2) so produced is not required to be transferred over networks with a protected, secure network

09 10 15  
20

5

10

15

20

25

30

connection, for example employing Virtual Private Network (VPN) tunneling, Secure Shell (SSH), or SSL/TLS protocols. Therefore, the aforementioned methods offer an advantageous model for transmitting text, binary, audio, image, video and other types of data, for example, in public Internet networks or in web services and cloud services.

Additional aspects, advantages, features and objects of the present disclosure would be made apparent from the drawings and the detailed description of the illustrative embodiments construed in conjunction with the appended claims that follow.

It will be appreciated that features of the present disclosure are susceptible to being combined in various combinations without departing from the scope of the present disclosure as defined by the appended claims.

#### **DESCRIPTION OF THE DRAWINGS**

The summary above, as well as the following detailed description of illustrative embodiments, is better understood when read in conjunction with the appended drawings. For the purpose of illustrating the present disclosure, exemplary constructions of the disclosure are shown in the drawings. However, the present disclosure is not limited to specific methods and apparatus disclosed herein. Moreover, those in the art will understand that the drawings are not to scale. Wherever possible, like elements have been indicated by identical numbers.

Embodiments of the present disclosure will now be described, by way of example only, with reference to the following diagrams wherein:

FIG. 1 is a schematic illustration of an encoder for encoding and encrypting input data (D1) to generate corresponding encoded and encrypted data (E2) and a decoder for decrypting and decoding the encoded and encrypted data (E2) to generate corresponding decoded data (D3), wherein the encoder and the decoder collectively form a codec, in accordance with an embodiment of the present disclosure;

FIG. 2 is a schematic illustration of a flow chart depicting steps of a first integrated method of encoding and encrypting input data (D1) to generate

09 10 15

5

10

15

20

25

30

corresponding encoded and encrypted data (E2), in accordance with an embodiment of the present disclosure;

FIG. 3 is a schematic illustration of a flow chart depicting steps of a second integrated method of decrypting and decoding encoded and encrypted data (E2) to generate corresponding decoded data (D3), in accordance with an embodiment of the present disclosure;

FIG. 4 is a schematic illustration of a flow chart depicting steps of a third integrated method of encoding and encrypting input data (D1) to generate corresponding encoded and encrypted data (E2), in accordance with another embodiment of the present disclosure; and

FIG. 5 is a schematic illustration of a flow chart depicting steps of a fourth integrated method of decrypting and decoding encoded and encrypted data (E2) to generate corresponding decoded data (D3), in accordance with another embodiment of the present disclosure.

In the accompanying diagrams, an underlined number is employed to represent an item over which the underlined number is positioned or an item to which the underlined number is adjacent. A non-underlined number relates to an item identified by a line linking the non-underlined number to the item. When a number is non-underlined and accompanied by an associated arrow, the non-underlined number is used to identify a general item at which the arrow is pointing.

## DETAILED DESCRIPTION OF EMBODIMENTS

The following detailed description illustrates embodiments of the present disclosure and ways in which they can be implemented. Although the best mode of carrying out the present disclosure has been disclosed, those skilled in the art would recognize that other embodiments for carrying out or practicing the present disclosure are also possible.

In overview, embodiments of the present disclosure are concerned with a data encryption method integrated into an encoder, *mutatis mutandis* a data decryption method integrated into a decoder. Data encoded and encrypted by the encoder using the aforementioned integrated encrypting method cannot be decrypted and decoded without employing a similar integration into an associated decoder.

09 10 15  
20

In the present disclosure, there is described an encrypting process that is integrated into an encoding process of a given encoder being used. This makes an associated encryption considerably stronger, without weakening a performance and capacity of an encryption algorithm employed by the encrypting process. The aforementioned integrated method beneficially uses already-known encryption algorithms. Integration of the encryption process is optionally implemented in encoders that encode data blocks and/or data packets and process one-dimensional or multi-dimensional text, binary, audio, image, video or other types of data.

Embodiments of the present disclosure seek to provide a cost-efficient way to encrypt data, by reducing a complexity of encryption algorithms, thereby saving on computing resources and processing energy expended by data processors. Moreover, with identical encryption algorithm settings, embodiments of the present disclosure offer considerably stronger protection than prior art solutions. This means, for example, that there will be no need to add extra computing resources to achieve a better data protection level.

It will be evident to a person skilled in the art that unencrypted information is called "*plaintext*", and correspondingly, encrypted information is called "*ciphertext*" throughout the present disclosure.

Referring to FIG. 1, embodiments of the present disclosure concern:

- (i) an encoder **110** for encoding and encrypting input data (D1) to generate corresponding encoded and encrypted data (E2), and corresponding methods of encoding and encrypting the input data (D1) to generate the encoded and encrypted data (E2);
- (ii) a decoder **120** for decrypting and decoding the encoded and encrypted data (E2) to generate corresponding decoded data (D3), and corresponding methods of decrypting and decoding the encoded and encrypted data (E2) to generate the decoded data (D3); and
- (iii) a codec **130** including a combination of at least one encoder and at least one decoder, namely a combination of the encoder **110** and the decoder **120**.

Optionally, the decoded data (D3) is exactly similar to the input data (D1), as in a lossless mode of operation. Alternatively, optionally, the decoded data (D3) is approximately similar to the input data (D1), as in a lossy mode of operation. Yet alternatively, optionally, the decoded data (D3) is different to the input data (D1), for example by way of a transformation, but retains substantially similar information present in the input data (D1); for example, the decoded data (D3) is usefully made different to the input data (D1) when reformatting of the decoded data (D3) is also required, for example to be compatible with different types of communication platforms, software layers, communication devices, and so forth.

10

The encoder **110** includes a data processing arrangement for processing the input data (D1) to generate the corresponding encoded and encrypted data (E2). Optionally, the data processing arrangement of the encoder **110** is implemented by employing at least one Reduced Instruction Set Computing (RISC) processor that is operable to execute program instructions as will be elucidated in detail below; such a RISC processor is capable of performing relatively simpler concatenated operations at very great speed, and suitable for encoding and decoding data provided in a streamed format, for example in real-time.

15

Optionally, the data processing arrangement of the encoder **110** is operable to encode and encrypt the input data (D1) provided in a form of at least one of: one-dimensional data, multi-dimensional data, text data, binary data, sensor data, audio data, image data, video data, but not limited thereto. Optionally, the input data (D1) is received as a stream or a file. The input data (D1) includes a plurality of data blocks and/or data packets.

25

Optionally, the data processing arrangement of the encoder **110** is supplied in operation with at least one key for use in generating the encoded and encrypted data (E2). Alternatively, optionally, the data processing arrangement of the encoder **110** is operable to generate the at least one key using a suitable key generation algorithm.

30

The data processing arrangement of the encoder **110** is operable to encode a first data block and/or data packet of the plurality of data blocks and/or data packets to generate a first encoded data block and/or data packet. The data processing

09 10 15

arrangement of the encoder **110** is then operable to encrypt the first encoded data block and/or data packet using the at least one key to provide a first encoded and encrypted data block and/or data packet for inclusion in the encoded and encrypted data (E2).

5

Moreover, the data processing arrangement of the encoder **110** is operable to generate a first seed value for use in encrypting a next encoded data block and/or data packet to provide a next encoded and encrypted data block and/or data packet for inclusion in the encoded and encrypted data (E2). Subsequently, the data processing arrangement of the encoder **110** is operable to generate a next seed value for use in encrypting a subsequent encoded data block and/or data packet, in a sequential repetitive manner until the plurality of data blocks and/or data packets are encoded and encrypted into the encoded and encrypted data (E2).

10

15

Optionally, the plurality of data blocks and/or data packets are encoded and encrypted one-by-one, in phases, into the encoded and encrypted data (E2), namely in a form of a plurality of encoded and encrypted data blocks and/or data packets.

09 10 15

20

It will be appreciated that a technical implementation of the encoder **110** may vary depending on an encoding algorithm and an encryption algorithm being used to perform an encoding process and an encrypting process, respectively. Nonetheless, the technical implementation integrates the encoding and encrypting processes. In other words, it will be appreciated that a selected encryption algorithm is beneficially included, namely embedded, into the encoder **110**.

25

The integration aims to generate a seed value for each subsequent data block and/or data packet to be encoded and encrypted based on its previous data block and/or data packet. As a result, subsequent decryption of each encoded and encrypted data block and/or data packet is dependent upon decryption and decoding of its previous encoded and encrypted data block and/or data packet, namely in the sequential repetitive manner as will be elucidated in greater detail below. Such a sequential repetitive manner of encryption by employing seed values enhances an operation of the encryption algorithm, as an intruding attacker will have to produce an entire

30

functionality of both the encoder **110** and the decoder **120** to be able to find a possible solution for decrypting and decoding the encoded and encrypted data (E2).

In an alternative implementation, a given data block and/or data packet can be first encrypted, and then be encoded into the encoded and encrypted data (E2). However, it will be appreciated that performing encoding of data blocks and/or data packets before encrypting is advantageous, as the input data (D1) often includes a lot of small variations in subsequent data blocks and/or data packets as compared to previous data blocks and/or data packets, namely partial or full duplicates of previous data blocks and/or data packets. Thus, the data processing arrangement of the encoder **110** is operable to employ a suitable data de-duplication technique to encode the plurality of data blocks and/or data packets of the input data (D1) into a plurality of encoded data blocks and/or data packets. As one example, a method described in GB 1411451.6 can be used to encode the plurality of data blocks and/or data packets. As another example, a method described in GB 1411531.5 can be used to encode the plurality of data blocks and/or data packets.

Moreover, optionally, the data processing arrangement of the encoder **110** is operable to perform an additional encoding process on the plurality of encoded data blocks and/or data packets, before or after the plurality of encoded data blocks and/or data packets are encrypted. For this purpose, the data processing arrangement of the encoder **110** is optionally operable to employ at least one of: entropy-modifying encoding, delta encoding, ODelta encoding, 1u or 8u range encoding, Run Length Encoding (RLE), Split RLE (SRLE), and/or interpolation encoding. Herein, the term "*delta encoding*" refers to a way of storing or transmitting data in a form of differences between sequential data rather than complete data files, while the term "*ODelta*" refers to a differential form of encoding based upon wraparound in a binary counting regime, for example as described in a patent document GB 1303661.1 , hereby incorporated by reference. The term "SRLE" or "Split RLE" refers to Split Run-Length Encoding method as described in a patent document GB 1303660.3

In an example, the data processing arrangement of the encoder **110** is optionally operable to compress further the plurality of encoded data blocks and/or data

09 10 15  
20

5

10

15

20

25

30

packets before encryption, by employing one or more suitable entropy-modifying encoding methods.

As an example, a Gurulogic Multi-Variate Codec (GMVC®) coding solution available from Gurulogic Microsystems Oy is beneficially used. The GMVC® is able to encode different types of data very efficiently, while producing several different data streams that contain an entire information of an original input, namely the input data (D1), efficiently in an entropy-encoded manner. For example, in the aforementioned proprietary GMVC® coding solution, encoding of image data or video data employs mutually different methods to produce various different data streams, depending on content of the input data (D1), as described in patent documents GB 2503295A ("Encoder and method") and GB2505169A ("Decoder and method"). Therefore, it is advantageous that different types of data are compressed efficiently with different entropy encoders that are optimal for precisely those types of data, while taking into account a bit count and an entropy of the input data (D1), before encrypting to generate the encoded and encrypted data (E2).

In this regard, optionally, the data processing arrangement, for example implemented using one or more aforesaid RISC processors, of the encoder **110** is operable to encode and encrypt the input data (D1) to generate the corresponding encoded and encrypted data (E2) in the sequential repetitive manner by branching to a plurality of concurrent sequences of encoding and encrypting of data blocks and/or data packets using associated seed values; such a RISC processor is capable of performing relatively simpler concatenated operations at very great speed, and suitable for encoding and decoding data provided in a streamed format, for example in real-time.

. This allows running several concurrent processes in a parallel manner to provide more rapid processing of the input data (D1), as well as providing an enhanced degree of encryption security, because the decoder **120** is required to employ a similar form of branching when decoding the encoded and encrypted data (E2).

Optionally, in order to implement branching, the input data (D1) is sub-divided into different streams of data blocks and/or data packets, for example, for each type of data present in the input data (D1). Beneficially, different encoding and encryption algorithms are used for different data streams.

09 10 15

5

10

15

20

25

30



Additionally or alternatively, optionally, branching can be usefully implemented to make the encoding and encrypting processes faster, even when the input data (D1) includes a same type of data. In this regard, the encoded and encrypted data (E2) optionally includes information indicative of how the input data (D1) is divided to implement the branching, for use in subsequent decrypting and decoding of the encoded and encrypted data (E2).

Optionally, the data processing arrangement of the encoder **110** is operable to use the at least one key repetitively in combination with the seed values for encrypting encoded data blocks and/or data packets for inclusion in the encoded and encrypted data (E2). In an example, the data processing arrangement of the encoder **110** is optionally operable to prepend the seed values to the at least one key for encrypting the encoded data blocks and/or data packets. In another example, the data processing arrangement of the encoder **110** is optionally operable to append the seed values to the at least one key for encrypting the encoded data blocks and/or data packets.

Alternatively, optionally, the data processing arrangement of the encoder **110** is operable to use the at least one key only for encrypting the first encoded data block and/or data packet. In such a case, the data processing arrangement of the encoder **110** is optionally operable to use the seed values alone for encrypting subsequent encoded data blocks and/or data packets for inclusion in the encoded and encrypted data (E2).

Moreover, optionally, the data processing arrangement of the encoder **110** is operable to employ an initialization vector (IV) in combination with the at least one key for encrypting the first encoded data block and/or data packet.

Furthermore, in one technical implementation model employed in an embodiment of the present disclosure, an intercept functionality is written into the encoder **110** to enable generation of the seed values, namely to call program routines or functions for generating the seed values.

09 10 15

5

10

15

20

25

30

In one embodiment of the present disclosure, information used to generate the seed values is defined or delivered to the decoder **120**, so that the encrypting process can be reversed during subsequent decryption. In this regard, the data processing arrangement of the encoder **110** is optionally operable to include in the encoded and encrypted data (E2) information indicative of at least one algorithm employed for generating the seed values for use in encrypting the encoded data blocks and/or data packets.

Varying seed values between the data blocks and/or data packets improves an efficiency of the encrypting process.

The seed values can be computed from potentially almost any sort of information present in the input data (D1). However, it will be appreciated that a seed value is beneficially not computed from processed data providing substantially the encoded and encrypted data (E2), because then the integration of the encoding and encrypting processes would not produce a seed value whose generation, during subsequent decryption at the decoder **120**, would require an interpretation of the encoding and encrypting processes. In other words, a seed value is beneficially computed from varying instantaneous information produced by the encoding process that cannot be directly derived from the encoded and encrypted data (E2) alone.

In one implementation, a seed value is computed before the encoding process is performed by using, for example, a check sum or a hash function. This potentially makes an associated decryption process slightly simpler, but still improved as compared with known prior art methods. In an example, the check sum or the hash function is computed on at least a portion of a given data block and/or data packet of the input data (D1).

In another implementation, a seed value is computed before the encrypting process is performed by using a Cipher-Block Chaining (CBC) mode of an Advanced Encryption Standard (AES) encryption algorithm. In such a case, an encrypted output of a previous data block and/or data packet, namely ciphertext, is combined with a given data block and/or data packet being encrypted, namely plaintext. This means that the CBC mode of the AES encryption algorithm works otherwise as normally, but

09 10 15  
20

5

10

15

20

25

30

the seed value generated by the encoding process is inserted into an encrypted output, namely the encoded and encrypted data (E2).

There are several optional ways in which seed values can be computed, used and/or transmitted for such a seed-based encryption, in embodiments of the present disclosure. These options depend, for example, upon a given usage scenario and/or target of the encoded and encrypted data (E2), and/or upon the encryption algorithm employed for the encrypting process.

In an alternative embodiment of the present disclosure, information which is at least partially indicatively as to how the seed values are generated is optionally transmitted from the encoder **110** to the decoder **120**, if the information used to generate the seed values is not otherwise defined or delivered to the decoder **120**. This is particularly beneficial in a case where the seed values are not related to the input data (D1) or are generated randomly. However, for security reasons, it is desirable that seed values as such are never transmitted for security reasons.

Furthermore, optionally, the encoder **110** is operable to communicate the encoded and encrypted data (E2) to a data server and/or data storage (not shown in FIG. 1) for storing in a database (not shown in FIG. 1). The data server and/or data storage is arranged to be accessible to the decoder **120**, which is beneficially compatible with the encoder **110**, for subsequently decrypting and decoding the encoded and encrypted data (E2).

Additionally, optionally, the encoder **110** is operable to communicate the at least one key and/or the initialization vector IV and/or the information indicative of the at least one algorithm employed for generating the seed values to the data server and/or data storage for storing in the database.

In some examples, the decoder **120** is optionally operable to access the encoded and encrypted data (E2) from the data server and/or data storage. Additionally, optionally, the decoder **120** is operable to access the at least one key and/or the IV and/or the information indicative of the at least one algorithm employed for

09 10 15  
20

5

10

15

20

25

30

generating the seed values from the data server and/or another data server and/or data storage.

In alternative examples, the encoder **110** is optionally operable to stream the encoded and encrypted data (E2) to the decoder **120**, either via a communication network or via a direct connection. Moreover, it is to be noted that a device equipped with a hardware-based or software-based encoder can also communicate directly with another device equipped with a hardware-based or software-based decoder.

In yet other alternative examples, the decoder **120** is optionally implemented so as to retrieve the encoded and encrypted data (E2) from a non-transitory (namely non-transient) computer-readable storage medium, such as a hard drive and a Solid-State Drive (SSD).

Moreover, optionally, the data processing arrangement of the encoder **110** is operable to arrange for delivery of the at least one key from the encoder **110** to the decoder **120**, for use in subsequent decrypting and decoding of the encoded and encrypted data (E2). Optionally, the at least one key is delivered from the encoder **110** to the decoder **120** manually between respective users thereof. Alternatively, optionally, the at least one key is delivered from the encoder **110** to the decoder **120** via an encrypted e-mail, for example, such as via an e-mail which is encrypted using Pretty Good Privacy (PGP), GNU Privacy Guard (GnuPG), or similar. Yet alternatively, optionally, the at least one key is delivered from the encoder **110** to the decoder **120** via an encrypted communication connection. Optionally, the encrypted communication connection is implemented via Secure Sockets Layer (SSL)/Transport Layer Security (TLS).

The decoder **120** includes a data processing arrangement for processing the encoded and encrypted data (E2) to generate the corresponding decoded data (D3).

Optionally, the data processing arrangement of the decoder **120** is implemented by employing at least one RISC processor that is operable to execute program instructions as will be elucidated in detail later; such a RISC processor is capable of performing relatively simpler concatenated operations at very great speed, and

09 10 15

15

20

25

30

suitable for encoding and decoding data provided in a streamed format, for example in real-time.

5 Optionally, the data processing arrangement of the decoder **120** is operable to decrypt and decode the encoded and encrypted data (E2) provided in a form of at least one of: encoded and encrypted one-dimensional data, encoded and encrypted multi-dimensional data, encoded and encrypted text data, encoded and encrypted binary data, encoded and encrypted sensor data, encoded and encrypted audio data, encoded and encrypted image data, encoded and encrypted video data, but not  
10 limited thereto.

As described earlier, the data processing arrangement of the decoder **120** is supplied in operation with the at least one key for use in generating the decoded data (D3).

15 The data processing arrangement of the decoder **120** is operable to decrypt a first encoded and encrypted data block and/or data packet of the plurality of encoded and encrypted data blocks and/or data packets using the at least one key to generate a first encoded data block and/or data packet. The data processing arrangement of the decoder **120** is then operable to decode the first encoded data block and/or data packet to provide a first decoded data block and/or data packet for inclusion in the  
20 decoded data (D3).

As described earlier, the encoded and encrypted data (E2) beneficially includes the information indicative of the at least one algorithm employed at the encoder **110** for  
25 generating the seed values for use in encrypting the encoded data blocks and/or data packets. Using this information, the data processing arrangement of the decoder **120** is operable to generate a first seed value for use in decrypting a next encoded and encrypted data block and/or data packet of the plurality of encoded and encrypted data blocks and/or data packets to generate a next encoded data block and/or data  
30 packet. The data processing arrangement of the decoder **120** is then operable to decode the next encoded data block and/or data packet to provide a next decoded data block and/or data packet for inclusion in the decoded data (D3).

09 10 15

Subsequently, the data processing arrangement of the decoder **120** is operable to generate a next seed value for use in decrypting and decoding a subsequent encoded and encrypted data block and/or data packet of the plurality of encoded and encrypted data blocks and/or data packets, in a sequential repetitive manner until the plurality of encoded and encrypted data blocks and/or data packets of the encoded and encrypted data (E2) are decrypted and decoded into the decoded data (D3).

In this manner, optionally, the plurality of encoded and encrypted data blocks and/or data packets of the encoded and encrypted data (E2) are decrypted and decoded one-by-one, in phases, into the decoded data (D3).

Moreover, optionally, in order to generate the decoded data (D3), the data processing arrangement of the decoder **120** is operable to perform a reverse of an encoding and encrypting process performed by the data processing arrangement of the encoder **110**. In this regard, optionally, the data processing arrangement of the decoder **120** is operable to perform an additional decoding process on the encoded data blocks and/or data packets by employing at least one of: entropy-modifying decoding, delta decoding, ODelta decoding, 1u or 8u range decoding, run length decoding, split run length decoding, and/or interpolation decoding.

Moreover, optionally, the data processing arrangement of the decoder **120** is operable to decrypt and decode the encoded and encrypted data (E2) to generate the corresponding decoded data (D3) in the sequential repetitive manner by branching to a plurality of concurrent sequences of decrypting and decoding of encoded and encrypted data blocks and/or data packets using associated seed values. Optionally, in order to implement such branching, the encoded and encrypted data (E2) includes different steams of encoded and encrypted data blocks and/or data packets, for example, for each different type of data present in the input data (D1).

Optionally, the data processing arrangement of the decoder **120** is operable to use the at least one key repetitively in combination with the seed values for decrypting the encoded and encrypted data blocks and/or data packets of the encoded and encrypted data (E2). In an example, the data processing arrangement of the decoder

09 10 15  
20

5

10

15

20

25

30

**120** is optionally operable to prepend the seed values to the at least one key for decrypting the encoded and encrypted data blocks and/or data packets. In another example, the data processing arrangement of the decoder **120** is optionally operable to append the seed values to the at least one key for decrypting the encoded and encrypted data blocks and/or data packets.

Alternatively, optionally, the data processing arrangement of the decoder **120** is operable to use the at least one key only for decrypting the first encoded and encrypted data block and/or data packet. In such a case, the data processing arrangement of the decoder **120** is optionally operable to use the seed values alone for decrypting subsequent encoded and encrypted data blocks and/or data packets.

Moreover, optionally, the data processing arrangement of the decoder **120** is operable to employ an initialization vector (IV) in combination with the at least one key for decrypting the first encoded and encrypted data block and/or data packet.

Furthermore, optionally, during encoding, a given data block and/or data packet is processed to generate a seed value for use in encrypting its subsequent data block and/or data packet. As a result, the seed value is based on contents of the given data block and/or data packet. Thus, during decrypting and decoding, a given encoded and encrypted data block and/or data packet needs to be decrypted and decoded correctly to enable decrypting and decoding a subsequent encoded and encrypted data block and/or data packet correctly. In this manner, generation of the decoded data (D3) from the encoded and encrypted data (E2) requires performing decrypting and decoding of the plurality of encoded and encrypted data blocks and/or data packets one-by-one, in phases.

The aforementioned integration of the encoding and encrypting processes increases an amount of computing resources that an intruding attacker will require to break an encryption so achieved. As a result, a time required in attempting to break the encryption potentially presents a novel challenge to cryptanalysts.

From a technical point of view, it is cost-efficient to encode the plurality of data blocks and/or data packets of the input data (D1) before encrypting, for example by way of

09 10 15  
20

5

10

15

20

25

30

data compression, because in such a case, an entropy and a data size of the encoded and encrypted data (E2) is smaller than if the input data (D1) were encrypted before compression. The encryption algorithm typically tends to produce maximum data entropy in the encoded and encrypted data (E2), which mathematically means that there are as many alternatives for deciphering the encoded and encrypted data (E2) as is theoretically possible.

FIG. 1 is merely an example, which should not unduly limit the scope of the claims herein. It is to be understood that the specific designation for the codec **130** is provided as an example and is not to be construed as limiting the codec **130** to specific numbers, types, or arrangements of encoders and decoders. A person skilled in the art will recognize many variations, alternatives, and modifications of embodiments of the present disclosure.

Optionally, the codec **130** is implemented within a single device. Alternatively, optionally, the codec **130** is effectively implemented between multiple devices. Optionally, the codec **130** is implemented as custom-design digital hardware, for example via use of one or more application-specific integrated circuits (ASIC's). Alternatively, or additionally, the codec is implemented in computer software instructions executable upon computing hardware.

The codec **130** can be implemented as at least one of: a data codec, an audio codec, an image codec and/or a video codec, but not limited thereto.

Moreover, the codec **130** can be implemented to provide a secure communication between senders and receivers, while considerably saving network bandwidth required for data transfer, and without requiring an encrypted communication connection, such as SSL/TLS, for data transfer. In an example, the codec **130** can be implemented in such systems that are based on request-response type communications, such as HyperText Transfer Protocol (HTTP) that is used in web browsers and World Wide Web (www) servers for data transfer.

Although it is probable that data encrypted today can be broken into and decrypted by using a "*brute force attack*" technique in the future, it is assumed that future

09 10 15  
20



encryption algorithms will correspondingly generate stronger encryption keys than current encryption algorithms, thus still ensuring strong encryption of data.

5 In addition to the “*brute force attack*” technique, there are other well-known attack techniques, such as “*biclique attack*”, “*related-key attack*”, “*padding oracle attack*”, “*length extension attack*” techniques and so forth, but these techniques essentially fail in breaking the encryption performed by the encoder **110**.

10 For illustration purposes only, there is next provided a technical example of an encrypting process as executed within the encoder **110**. In this example, one generally efficient model is presented for encrypting an unencrypted plaintext data stream by using a symmetric AES encryption algorithm in CBC mode and a seed value with an expanded encryption key pursuant to following steps:

- 15
1. Obtain or generate two encryption keys, namely *Key1* and *Key2*;
  2. Generate cryptographic random Initialization Vector (IV) bytes for AES CBC;
  3. Encrypt Plaintext bytes (namely, encoded data blocks and/or data packets) to Ciphertext bytes (namely, encoded and encrypted data blocks and/or data packets) using AES CBC function with *Key1* and IV or *Key1* and Salt;
  - 20 4. Merge IV and Ciphertext bytes;
  5. Create Message Authentication Code (MAC) bytes using HMAC function with *Key2* and Ciphertext; and
  6. Write MAC and Ciphertext bytes to data stream, namely encoded and encrypted data (E2).

25

Moreover, a pseudo code for the aforementioned algorithm is presented as follows:

```
Key1 = KeyStretch(GetKey())
Key2 = KeyStretch(GetKey())
30 IV = Random()
Ciphertext = IV + AES(Key1 + Salt, IV, Plaintext)
MAC = HMAC(Key2, Ciphertext)
DATA = MAC + Ciphertext
```

In the example above, two strengthened keys have been created using a “*key stretching*” technique. The “*key stretching*” technique is typically implemented by running a password for encrypting thousands of times through a one-way digest algorithm, namely a hashing algorithm. This creates enough permutations to protect the password from attacks, namely key-related attacks.

Thereafter, corresponding random Initialization Vector (IV) bytes are created for the CBC mode. These IV bytes are then scrambled and blended into a first encoded data block and/or data packet to be encrypted. The first encoded data block and/or data packet is then encrypted using the symmetric AES encryption algorithm in the CBC mode with a multiply expanded key and IV bytes.

Using the IV bytes for the first encoded data block and/or data packet is particularly beneficial for purposes of improving a degree of protection of the encryption thereby obtained, for example, in cases where the input data (D1) contains a lot of redundant data. As a result, an intruding attacker cannot decrypt an entire sequence of information, namely the input data (D1), before each encoded and encrypted data block and/or data packet of the encoded and encrypted data (E2) has been broken from start to finish.

Next, subsequent encoded data blocks and/or data packets are encrypted using the symmetric AES encryption algorithm in the CBC mode with a multiply expanded key and seed values generated by the encoding process.

Finally, Message Authentication Code (MAC) bytes are inserted into the Ciphertext, namely into the encoded and encrypted data (E2). This prevents possibly identical ciphertext caused by possibly occurring redundant plaintext in the input data (D1), and also prevents the encryption from being broken, for example via a “*padding oracle attack*” technique. This also ensures that the integrity of the encoded and encrypted data (E2) is intact.

Referring now to FIG. 2, there is provided a flow chart depicting steps of a first integrated method of encoding and encrypting input data (D1), including a plurality of data blocks and/or data packets, to generate corresponding encoded and encrypted

09 10 15  
20

5

10

15

20

25

30

data (E2), in accordance with an embodiment of the present disclosure. The method is depicted as a collection of steps in a logical flow diagram, which represents a sequence of steps that can be implemented in hardware, software, or a combination thereof, for example as aforementioned.

5

For illustration purposes only, the method will next be illustrated with reference to the encoder **110** depicted in FIG. 1.

At a step **202**, the data processing arrangement of the encoder **110** reads or receives  
10 a first data block and/or data packet of the plurality of data blocks and/or data packets.

Next, at a step **204**, the data processing arrangement of the encoder **110** encodes  
15 the first data block and/or data packet to generate a first encoded data block and/or data packet.

Optionally, at the step **204**, the data processing arrangement of the encoder **110**  
20 processes the first data block and/or data packet to generate a first seed value for use in encryption of a next data block and/or data packet of the plurality of data blocks and/or data packets. The seed value is interchangeably referred to as "salt" hereinafter.

Subsequently, at a step **206**, the data processing arrangement of the encoder **110**  
25 encrypts the first encoded data block and/or data packet using at least one key to provide a first encoded and encrypted data block and/or data packet for inclusion in the encoded and encrypted data (E2).

Optionally, the data processing arrangement of the encoder **110** is supplied with at least one key for use in generating the encoded and encrypted data (E2).  
30 Alternatively, optionally, the data processing arrangement of the encoder **110** generates the at least one key using a suitable key generation algorithm.

09 10 15

Additionally, optionally, the data processing arrangement of the encoder **110** employs an initialization vector (IV) in combination with the at least one key for encrypting the first encoded data block and/or data packet at the step **206**.

5 Next, at a step **208**, the data processing arrangement of the encoder **110** writes or transmits the first encoded and encrypted data block and/or data packet in the encoded and encrypted data (E2).

10 At a step **210**, the data processing arrangement of the encoder **110** reads or receives the next data block and/or data packet of the plurality of data blocks and/or data packets.

15 Next, at a step **212**, the data processing arrangement of the encoder **110** encodes the next data block and/or data packet to generate a next encoded data block and/or data packet.

20 09 10 15  
Optionally, at the step **212**, the data processing arrangement of the encoder **110** processes the next data block and/or data packet to generate a next seed value for use in encryption of a subsequent data block and/or data packet of the plurality of data blocks and/or data packets.

25 Subsequently, at a step **214**, the data processing arrangement of the encoder **110** encrypts the next encoded data block and/or data packet using the first seed value generated at the step **204** in combination with the at least one key to provide a next encoded and encrypted data block and/or data packet for inclusion in the encoded and encrypted data (E2).

30 For this purpose, the first seed value and the at least one key can be merged in various ways. As an example, the at least one key is salted by prepending or appending the first seed value to the at least one key.

Next, at a step **216**, the data processing arrangement of the encoder **110** writes or transmits the next encoded and encrypted data block and/or data packet in the encoded and encrypted data (E2).

Likewise, at a step **218**, the data processing arrangement of the encoder **110** reads or receives the subsequent data block and/or data packet of the plurality of data blocks and/or data packets.

5

Next, at a step **220**, the data processing arrangement of the encoder **110** encodes the subsequent data block and/or data packet to generate a subsequent encoded data block and/or data packet.

10

Optionally, at the step **220**, the data processing arrangement of the encoder **110** processes the subsequent data block and/or data packet to generate a subsequent seed value (not shown in FIG. 2) for use in encryption of a yet subsequent data block and/or data packet of the plurality of data blocks and/or data packets.

15

Subsequently, at a step **222**, the data processing arrangement of the encoder **110** encrypts the subsequent encoded data block and/or data packet using the next seed value generated at the step **212** in combination with the at least one key to provide a subsequent encoded and encrypted data block and/or data packet for inclusion in the encoded and encrypted data (E2). For this purpose, the next seed value and the at least one key can be merged, for example, by prepending or appending the next seed value to the at least one key.

09 10 15

20

Next, at a step **224**, the data processing arrangement of the encoder **110** writes or transmits the subsequent encoded and encrypted data block and/or data packet in the encoded and encrypted data (E2).

25

The steps **218** to **224** are performed in a sequential repetitive manner until the plurality of data blocks and/or data packets of the input data (D1) are encoded and encrypted into the encoded and encrypted data (E2).

30

The steps **202** to **224** are only illustrative and other alternatives can also be provided where one or more steps are added, one or more steps are removed, or one or more steps are provided in a different sequence without departing from the scope of the claims herein. In an alternative embodiment, encoding of the plurality of data blocks

and/or data packets is performed, before encrypting of their corresponding encoded data blocks and/or data packets begins. In other words, the steps **202**, **204**, **210**, **212**, **218** and **220**, namely the steps pertaining to reading and encoding of data blocks and/or data packets of the input data (D1), are performed before the steps **206**, **208**, **214**, **216**, **222** and **224**, namely the steps pertaining to encrypting of encoded data blocks and/or data packets and writing to the encoded and encrypted data (E2), are performed.

As shown in FIG. 2, the steps **206**, **214** and **222** are optionally performed using the CBC mode of the symmetric AES encryption algorithm. The step **206** is optionally performed using a randomly-generated IV, which is merged with the at least one key. The steps **214** and **222** are performed using their associated salts, namely the seed values generated at the steps **204** and **212**, respectively. In an example, a base 64 version of value bits associated with a given data block and/or data packet is used as a salt for its subsequent data block and/or data packet.

It will be appreciated that the method depicted in FIG. 2 can be implemented using other encryption algorithms, irrespective of whether or not IV is used for encrypting the first encoded data block and/or data packet, and irrespective of whether or not the chained CBC mode is used.

Embodiments of the present disclosure provide a computer program product comprising a non-transitory (namely non-transient) computer-readable storage medium having computer-readable instructions stored thereon, the computer-readable instructions being executable by a computerized device comprising processing hardware to execute the first integrated method as described in conjunction with FIG. 2. The computer-readable instructions are optionally downloadable from a software application store, for example, from an "App store" to the computerized device.

FIG. 3 is a schematic illustration of a flow chart depicting steps of a second integrated method of decrypting and decoding encoded and encrypted data (E2), including a plurality of encoded and encrypted data blocks and/or data packets, to generate corresponding decoded data (D3), in accordance with an embodiment of

09 10 15  
20

5

10

15

20

25

30

the present disclosure. The method is depicted as a collection of steps in a logical flow diagram, which represents a sequence of steps that can be implemented in hardware, software, or a combination thereof.

5 For illustration purposes only, the method will next be illustrated with reference to the decoder **120** depicted in FIG. 1.

At a step **302**, the data processing arrangement of the decoder **120** reads or receives a first encoded and encrypted data block and/or data packet of the plurality of  
10 encoded and encrypted data blocks and/or data packets.

Next, at a step **304**, the data processing arrangement of the decoder **120** decrypts the first encoded and encrypted data block and/or data packet using at least one key to generate a first encoded data block and/or data packet.

15 Optionally, the data processing arrangement of the decoder **120** is supplied with the at least one key for use in generating the decoded data (D3).

20 Additionally, optionally, the data processing arrangement of the decoder **120** employs an initialization vector (IV) in combination with the at least one key for decrypting the first encoded and encrypted data block and/or data packet at the step **304**.

25 Subsequently, at a step **306**, the data processing arrangement of the decoder **120** decodes the first encoded data block and/or data packet to provide a first decoded data block and/or data packet for inclusion in the decoded data (D3).

30 Optionally, at the step **306**, the data processing arrangement of the decoder **120** processes the first decoded data block and/or data packet to generate a first seed value for use in decryption of a next encoded and encrypted data block and/or data packet of the plurality of encoded and encrypted data blocks and/or data packets.

Next, at a step **308**, the data processing arrangement of the decoder **120** writes or transmits the first decoded data block and/or data packet in the decoded data (D3).

09 10 15  
20

At a step **310**, the data processing arrangement of the decoder **120** reads or receives the next encoded and encrypted data block and/or data packet of the plurality of encoded and encrypted data blocks and/or data packets.

5 Next, at a step **312**, the data processing arrangement of the decoder **120** decrypts the next encoded and encrypted data block and/or data packet using the first seed value generated at the step **306** in combination with the at least one key to generate a next encoded data block and/or data packet.

10 For this purpose, the first seed value and the at least one key can be merged in various ways. As an example, the at least one key is salted by prepending or appending the first seed value to the at least one key.

15 Subsequently, at a step **314**, the data processing arrangement of the decoder **120** decodes the next encoded data block and/or data packet to provide a next decoded data block and/or data packet for inclusion in the decoded data (D3).

20 Optionally, at the step **314**, the data processing arrangement of the decoder **120** processes the next decoded data block and/or data packet to generate a next seed value for use in decryption of a subsequent encoded and encrypted data block and/or data packet of the plurality of encoded and encrypted data blocks and/or data packets.

25 Next, at a step **316**, the data processing arrangement of the decoder **120** writes or transmits the next decoded data block and/or data packet in the decoded data (D3).

Likewise, at a step **318**, the data processing arrangement of the decoder **120** reads or receives the subsequent encoded and encrypted data block and/or data packet of the plurality of encoded and encrypted data blocks and/or data packets.

30

Next, at a step **320**, the data processing arrangement of the decoder **120** decrypts the subsequent encoded and encrypted data block and/or data packet using the next seed value generated at the step **314** in combination with the at least one key to generate a subsequent encoded data block and/or data packet.

09 10 15



For this purpose, the next seed value and the at least one key can be merged, for example, by prepending or appending the next seed value to the at least one key.

5 Subsequently, at a step **322**, the data processing arrangement of the decoder **120** decodes the subsequent encoded data block and/or data packet to provide a subsequent decoded data block and/or data packet for inclusion in the decoded data (D3).

10 Optionally, at the step **322**, the data processing arrangement of the decoder **120** processes the subsequent decoded data block and/or data packet to generate a subsequent seed value (not shown in FIG. 3) for use in decryption of a yet subsequent encoded and encrypted data block and/or data packet of the plurality of encoded and encrypted data blocks and/or data packets.

15 Next, at a step **324**, the data processing arrangement of the decoder **120** writes or transmits the subsequent decoded data block and/or data packet in the decoded data (D3).

20 The steps **318** to **324** are performed in a sequential repetitive manner until the plurality of encoded and encrypted data blocks and/or data packets of the encoded and encrypted data (E2) are decrypted and decoded into the decoded data (D3).

25 The steps **302** to **324** are only illustrative and other alternatives can also be provided where one or more steps are added, one or more steps are removed, or one or more steps are provided in a different sequence without departing from the scope of the claims herein.

30 As shown in FIG. 3, the steps **304**, **312** and **320** are optionally performed using the CBC mode of the symmetric AES encryption algorithm. The step **304** is optionally performed using a randomly-generated **IV**, which is merged with the at least one key. The steps **312** and **320** are performed using their associated salts, namely the seed values generated at the steps **306** and **314**, respectively. In an example, a base 64 version of value bits associated with a given decoded data block and/or data packet

09 10 15  
20

is used as a salt for a subsequent encoded and encrypted data block and/or data packet.

It will be appreciated that the method depicted in FIG. 3 can be implemented using other decryption algorithms, irrespective of whether or not IV is used for decrypting the first encoded and encrypted data block and/or data packet, and irrespective of whether or not the chained CBC mode is used.

Embodiments of the present disclosure provide a computer program product comprising a non-transitory (namely non-transient) computer-readable storage medium having computer-readable instructions stored thereon, the computer-readable instructions being executable by a computerized device comprising processing hardware to execute the second integrated method as described in conjunction with FIG. 3. The computer-readable instructions are optionally downloadable from a software application store, for example, from an "App store" to the computerized device.

FIG. 4 is a schematic illustration of a flow chart depicting steps of a third integrated method of encoding and encrypting input data (D1), including a plurality of data blocks and/or data packets, to generate corresponding encoded and encrypted data (E2), in accordance with another embodiment of the present disclosure. Description of the steps of the first integrated method depicted in FIG. 2 pertains *mutatis mutandis* to the steps of the third integrated method depicted in FIG. 4, except where stated otherwise. Specifically, the description of the steps **202**, **204**, **206**, **208**, **210**, **212**, **216**, **218**, **220** and **224** pertains *mutatis mutandis* to steps **402**, **404**, **406**, **408**, **410**, **412**, **416**, **418**, **420** and **424**, respectively.

A step **414** differs from the step **214** in that the first seed value is used alone, namely without the at least one key, for encrypting the next encoded data block and/or data packet. Likewise, a step **422** differs from the step **222** in that the next seed value is used alone for encrypting the subsequent encoded data block and/or data packet. Thus, in the third integrated method, the data processing arrangement of the encoder **110** is operable to use the at least one key only for encrypting the first encoded data block and/or data packet at the step **406**.

09 10 15  
20

5

10

15

20

25

30

Embodiments of the present disclosure provide a computer program product comprising a non-transitory (namely non-transient) computer-readable storage medium having computer-readable instructions stored thereon, the computer-readable instructions being executable by a computerized device comprising processing hardware to execute the third integrated method as described in conjunction with FIG. 4. The computer-readable instructions are optionally downloadable from a software application store, for example, from an “App store” to the computerized device.

FIG. 5 is a schematic illustration of a flow chart depicting steps of a fourth integrated method of decrypting and decoding encoded and encrypted data (E2), including a plurality of encoded and encrypted data blocks and/or data packets, to generate corresponding decoded data (D3), in accordance with another embodiment of the present disclosure. Description of the steps of the second integrated method depicted in FIG. 3 pertains *mutatis mutandis* to the steps of the fourth integrated method depicted in FIG. 5, except where stated otherwise. Specifically, the description of the steps **302**, **304**, **306**, **308**, **310**, **314**, **316**, **318**, **322** and **324** pertains *mutatis mutandis* to steps **502**, **504**, **506**, **508**, **510**, **514**, **516**, **518**, **522** and **524**, respectively.

A step **512** differs from the step **312** in that the first seed value is used alone, namely without the at least one key, for decrypting the next encoded and encrypted data block and/or data packet. Likewise, a step **520** differs from the step **320** in that the next seed value is used alone for decrypting the subsequent encoded and encrypted data block and/or data packet. Thus, in the fourth integrated method, the data processing arrangement of the decoder **120** is operable to use the at least one key only for decrypting the first encoded and encrypted data block and/or data packet at the step **504**.

Embodiments of the present disclosure provide a computer program product comprising a non-transitory (namely non-transient) computer-readable storage medium having computer-readable instructions stored thereon, the computer-readable instructions being executable by a computerized device comprising

09 10 15  
20

5

10

15

20

25

30

processing hardware to execute the fourth integrated method as described in conjunction with FIG. 5. The computer-readable instructions are optionally downloadable from a software application store, for example, from an “App store” to the computerized device.

5

The aforementioned first or third integrated methods are suitable for implementation into an encoder, or into a pre-processor associated with an encoder; for example, the aforementioned first or third integrated methods are suitable for use in conjunction with an existing known encryption method and complementary thereto. Similarly, the

10 aforementioned second and fourth integrated methods are suitable for implementation into a decoder or into a pre-processor associated with a decoder; for example, the aforementioned first or third integrated methods are suitable for use in conjunction with an existing known decryption method and complementary thereto.

15

The aforementioned methods can be implemented in software and/or via use of a hardwired logic, for example Application Specific Integrated Circuits (ASIC’s). It is well known that many systems have a dedicated microchip for encryption, for example contemporary AES, that implements the encryption efficiently, while using less power than a pure software approach. The aforementioned methods make it possible to achieve considerable power and energy savings, when compared to prior art approaches of using encryption with a corresponding strength against third-party attacks, for example against spyware.

09 10 15

20

Embodiments of the present disclosure facilitate a considerable protection improvement as compared with protection achieved with prior art methods using corresponding encryption algorithms. The methods pursuant to embodiments of the present disclosure can be implemented with any suitable encoding solution, irrespective of which encryption algorithm is used. In doing so, the aforementioned methods do not alter a behavior of an integrated encryption algorithm, which means that the protection provided by the integrated encryption algorithm is not

25 compromised. Thus, the methods pursuant to embodiments of the present disclosure strengthen further the prior art data compression and encryption algorithms by integrating them together to function in concert.

30

The methods pursuant to embodiments of the present disclosure are suitable for efficient utilization especially in medical or military purposes to protect vital information that is confidential or classified.

5 Moreover, the aforementioned methods can be implemented in connection with common, well-known open source or proprietary data compression software applications, such as 7-Zip or Win-Zip, and so forth (“7-Zip” and “Win-Zip” are proprietary trademarks).

10 Moreover, the integration of the encoding and encrypting processes offers an efficient model for multiprocessing, or running several processes in a parallel manner. The integration enables implementation of an optimal processing structure for a given Central Processing Unit (CPU) and a given Graphical Processing Unit (GPU) according to an available computing capacity. Thus, the aforementioned  
15 methods enable efficient threading of the integrated encryption process in the encoding process, when data blocks and/or data packets of the input data (D1) are optimized to a format that is optimal for the CPU and the GPU of a system and/or platform in which the encoding process is being run. Aforementioned branching during encryption and decryption enable parallel processing approaches to be  
20 employed, for example by allocating a dedicated data processing to each branch. Use of computing hardware such as digital array processors (DAP’s) for high-speed data encryption and corresponding decryption of data thereby becomes feasible.

The aforementioned methods make it possible to use a very fast, yet efficient  
25 encryption algorithm. In this regard, the aforementioned methods use an encryption algorithm efficiently, without interfering with an inner operation of the encryption algorithm itself. Examples of encryption algorithms that are suitable for implementation with the aforementioned methods include, but are not limited to, AES, Twofish, Blowfish, Data Encryption Standard (DES), Triple DES (3-DES), Serpent,  
30 International Data Encryption Algorithm (IDEA), MARS, Rivest Cipher 6 (RC6), Camellia, CAST-128, Skipjack, eXtended Tiny Encryption Algorithm (XTEA), and so forth (these example names include registered trademarks).

09 10 15

20

25

30

Moreover, an additional advantage of integrating the encryption process with the encoding process is that the encoded and encrypted data (E2) so produced is not required to be transferred over networks with a protected, secure network connection, for example employing Virtual Private Network (VPN) tunneling, Secure Shell (SSH), or SSL/TLS protocols. Therefore, the aforementioned methods offer an advantageous model for transmitting text, binary, audio, image, video and other types of data, for example, in public Internet networks or in web services and cloud services.

Embodiments of the present disclosure are susceptible to being employed in a wide range of systems and devices, for example, such as smart telephones, Personal Computers (PC's), audio-visual apparatus, cameras, communication networks, data storage devices, surveillance systems, video conferencing systems, medical apparatus, seismic apparatus, surveying apparatus, "black box" flight recorders, digital musical instruments using sampling techniques, but not limited thereto.

09 10 15

## CLAIMS

We claim:

5

1. An encoder (110) for encoding and encrypting input data (D1) including a plurality of data blocks and/or data packets, wherein the encoder (110) includes a data processing arrangement for processing the input data (D1) to generate corresponding encoded and encrypted data (E2), characterized in that:

10

(i) the data processing arrangement is operable to encode at least a first data block and/or data packet of the plurality of data blocks and/or data packets to generate a first encoded data block and/or data packet, and to encrypt the at least a first encoded data block and/or data packet using at least one key to provide a first encoded and encrypted data block and/or data packet for inclusion in the encoded and encrypted data (E2);

15

(ii) the data processing arrangement is operable to generate a first seed value for use in encrypting a next encoded data block and/or data packet to provide a next encoded and encrypted data block and/or data packet for inclusion in the encoded and encrypted data (E2); and

20

(iii) the data processing arrangement is operable to generate a next seed value for use in encrypting a subsequent encoded data block and/or data packet, in a sequential repetitive manner until the plurality of data blocks and/or data packets are encoded and encrypted into the encoded and encrypted data (E2).

25

2. An encoder (110) as claimed in claim 1, characterized in that the data processing arrangement is supplied in operation with the at least one key for use in generating the encoded and encrypted data (E2).

30

3. An encoder (110) as claimed in claim 1, characterized in that the data processing arrangement is operable to use the at least one key repetitively in combination with seed values for encrypting encoded data blocks and/or data packets for inclusion in the encoded and encrypted data (E2).

4. An encoder (110) as claimed in claim 1, characterized in that the data processing arrangement is operable to use the at least one key for encrypting the first encoded data block and/or data packet, alone.

5

5. An encoder (110) as claimed in claim 1, characterized in that the data processing arrangement is operable to employ an initialization vector (IV) in combination with the at least one key when encrypting the at least a first encoded data block and/or data packet.

10

6. An encoder (110) as claimed in claim 1, characterized in that the data processing arrangement is operable to include in the encoded and encrypted data (E2) information indicative of at least one algorithm employed for generating seed values for use in encrypting encoded data blocks and/or data packets.

15

7. An encoder (110) as claimed in claim 1, characterized in that the data processing arrangement is operable to encode and encrypt the input data (D1) to generate the corresponding encoded and encrypted data (E2) in the sequential repetitive manner by branching to a plurality of concurrent sequences of encoding and encrypting of data blocks and/or data packets using associated seed values.

20

8. An encoder (110) as claimed in claim 1, characterized in that the data processing arrangement is operable to encode and encrypt the input data (D1) provided in a form of at least one of: one-dimensional data, multi-dimensional data, text data, binary data, sensor data, audio data, image data, video data.

25

9. An encoder (110) as claimed in claim 1, characterized in that the data processing arrangement is operable to arrange for delivery of the at least one key from the encoder (110), for use in subsequent decrypting and decoding of the encoded and encrypted data (E2), manually or via an encrypted e-mail or via an encrypted communication connection.

30

14 07 17



10. An encoder (110) as claimed in claim 9, characterized in that the encrypted communication connection is implemented via Secure Sockets Layer (SSL)/Transport Layer Security (TLS) protocol.

5 11. An encoder (110) as claimed in claim 1, characterized in that the data processing arrangement is implemented by employing at least one Reduced Instruction Set Computing (RISC) processor that is operable to execute program instructions.

10 12. A method of encoding and encrypting input data (D1) including a plurality of data blocks and/or data packets, via an encoder (110), wherein the encoder (110) includes a data processing arrangement for processing the input data (D1) to generate corresponding encoded and encrypted data (E2), characterized in that the method includes:

- 15 (i) encoding a first data block and/or data packet of the plurality of data blocks and/or data packets to generate at least a first encoded data block and/or data packet;
- (ii) encrypting the at least a first encoded data block and/or data packet using at least one key to provide a first encoded and encrypted data block and/or data packet for inclusion in the encoded and encrypted data (E2);
- 20 (iii) generating a first seed value for use in encrypting a next encoded data block and/or data packet to provide a next encoded and encrypted data block and/or data packet for inclusion in the encoded and encrypted data (E2); and
- (iv) generating a next seed value for use in encrypting a subsequent encoded data
- 25 block and/or data packet, in a sequential repetitive manner until the plurality of data blocks and/or data packets are encoded and encrypted into the encoded and encrypted data (E2).

13. A method as claimed in claim 12, characterized in that the method includes

30 supplying the data processing arrangement with the at least one key for use in generating the encoded and encrypted data (E2).

14. A method as claimed in claim 12, characterized in that the method includes operating the data processing arrangement to use the at least one key repetitively in

14 07 17

combination with seed values for encrypting encoded data blocks and/or data packets for inclusion in the encoded and encrypted data (E2).

15. A method as claimed in claim 12, characterized in that the method includes  
5 operating the data processing arrangement to use the at least one key for encrypting  
the at least a first encoded data block and/or data packet, alone.

16. A method as claimed in claim 12, characterized in that the method includes  
operating the data processing arrangement to employ an initialization vector (IV) in  
10 combination with the at least one key when encrypting the first encoded data block  
and/or data packet.

17. A method as claimed in claim 12, characterized in that the method includes  
operating the data processing arrangement to include in the encoded and encrypted  
15 data (E2) information indicative of at least one algorithm employed for generating  
seed values for use in encrypting encoded data blocks and/or data packets.

18. A method as claimed in claim 12, characterized in that the method includes  
operating the data processing arrangement to encode and encrypt the input data  
20 (D1) to generate the corresponding encoded and encrypted data (E2) in the  
sequential repetitive manner by branching to a plurality of concurrent sequences of  
encoding and encrypting of data blocks and/or data packets using associated seed  
values.

19. A method as claimed in claim 12, characterized in that the method includes  
operating the data processing arrangement to encode and encrypt the input data  
25 (D1) provided in a form of at least one of: one-dimensional data, multi-dimensional  
data, text data, binary data, sensor data, audio data, image data, video data.

20. A method as claimed in claim 12, characterized in that the method includes  
operating the data processing arrangement to arrange for delivery of the at least one  
30 key from the encoder (110), for use in subsequent decrypting and decoding of the  
encoded and encrypted data (E2), manually or via an encrypted e-mail or via an  
encrypted communication connection.

21. A method as claimed in claim 20, characterized in that the method includes implementing the encrypted communication connection via Secure Sockets Layer (SSL)/Transport Layer Security (TLS) protocol.

5

22. A method as claimed in claim 12, characterized in that the method includes implementing the data processing arrangement by employing at least one Reduced Instruction Set Computing (RISC) processor that is operable to execute program instructions.

10

23. A decoder (120) for decrypting and decoding encoded and encrypted data (E2) including a plurality of encoded and encrypted data blocks and/or data packets, wherein the decoder (120) includes a data processing arrangement for processing the encoded and encrypted data (E2) to generate corresponding decoded data (D3), and wherein the decoder (120) is supplied in operation with at least one key for use in generating the decoded data (D3), characterized in that:

15

(i) the data processing arrangement is operable to decrypt at least a first encoded and encrypted data block and/or data packet of the plurality of encoded and encrypted data blocks and/or data packets using the at least one key to generate at least a first encoded data block and/or data packet, and to decode the at least first encoded data block and/or data packet to provide at least a first decoded data block and/or data packet for inclusion in the decoded data (D3);

20

(ii) the data processing arrangement is operable to generate a first seed value for use in decrypting a next encoded and encrypted data block and/or data packet of the plurality of encoded and encrypted data blocks and/or data packets to generate a next encoded data block and/or data packet, and to decode the next encoded data block and/or data packet to provide a next decoded data block and/or data packet for inclusion in the decoded data (D3); and

25

30

(iii) the data processing arrangement is operable to generate a next seed value for use in decrypting and decoding a subsequent encoded and encrypted data block and/or data packet of the plurality of encoded and encrypted data blocks and/or data packets, in a sequential repetitive manner until the plurality of

encoded and encrypted data blocks and/or data packets are decrypted and decoded into the decoded data (D3).

24. A decoder (120) as claimed in claim 23, characterized in that the data processing arrangement is operable to use the at least one key repetitively in combination with seed values for decrypting the plurality of encoded and encrypted data blocks and/or data packets.

25. A decoder (120) as claimed in claim 23, characterized in that the data processing arrangement is operable to use the at least one key for decrypting the first encoded and encrypted data block and/or data packet, alone.

26. A decoder (120) as claimed in claim 23, characterized in that the data processing arrangement is operable to employ an initialization vector (IV) in combination with the at least one key when decrypting the first encoded and encrypted data block and/or data packet.

27. A decoder (120) as claimed in claim 23, characterized in that the data processing arrangement is operable to decrypt and decode the encoded and encrypted data (E2) to generate the corresponding decoded data (D3) in the sequential repetitive manner by branching to a plurality of concurrent sequences of decrypting and decoding of encoded and encrypted data blocks and/or data packets using associated seed values.

28. A decoder (120) as claimed in claim 23, characterized in that the data processing arrangement is operable to decrypt and decode the encoded and encrypted data (E2) provided in a form of at least one of: encoded and encrypted one-dimensional data, encoded and encrypted multi-dimensional data, encoded and encrypted text data, encoded and encrypted binary data, encoded and encrypted sensor data, encoded and encrypted audio data, encoded and encrypted image data, encoded and encrypted video data.

29. A decoder (120) as claimed in claim 23, characterized in that the data processing arrangement is operable to arrange for receiving the at least one key at

the decoder (120), for use in subsequent decrypting and decoding of the encoded and encrypted data (E2), manually or via an encrypted e-mail or via an encrypted communication connection.

5 30. A decoder (120) as claimed in claim 29, characterized in that the encrypted communication connection is implemented via Secure Sockets Layer (SSL)/Transport Layer Security (TLS) protocol.

10 31. A decoder (120) as claimed in claim 23, characterized in that the data processing arrangement is implemented by employing at least one Reduced Instruction Set Computing (RISC) processor that is operable to execute program instructions.

15 32. A method of decrypting and decoding encoded and encrypted data (E2) including a plurality of encoded and encrypted data blocks and/or data packets, via a decoder (120), wherein the decoder (120) includes a data processing arrangement for processing the encoded and encrypted data (E2) to generate corresponding decoded data (D3), and wherein the decoder (120) is supplied in operation with at least one key for use in generating the decoded data (D3), characterized in that the method includes:

- 20
- (i) decrypting at least a first encoded and encrypted data block and/or data packet of the plurality of encoded and encrypted data blocks and/or data packets using the at least one key to generate at least a first encoded data block and/or data packet;
  - 25 (ii) decoding the at least first encoded data block and/or data packet to provide at least a first decoded data block and/or data packet for inclusion in the decoded data (D3);
  - (iii) generating a first seed value for use in decrypting and decoding a next encoded and encrypted data block and/or data packet of the plurality of encoded and encrypted data blocks and/or data packets to provide a next decoded data block and/or data packet for inclusion in the decoded data (D3);
  - 30 and
  - (iv) generating a next seed value for use in decrypting and decoding a subsequent encoded and encrypted data block and/or data packet of the plurality of

14 07 17

encoded and encrypted data blocks and/or data packets, in a sequential repetitive manner until the plurality of encoded and encrypted data blocks and/or data packets are decrypted and decoded into the decoded data (D3).

5 33. A method as claimed in claim 32, characterized in that the method includes operating the data processing arrangement to use the at least one key repetitively in combination with seed values for decrypting the plurality of encoded and encrypted data blocks and/or data packets.

10 34. A method as claimed in claim 32, characterized in that the method includes operating the data processing arrangement to use the at least one key for decrypting the at least first encoded and encrypted data block and/or data packet, alone.

15 35. A method as claimed in claim 32, characterized in that the method includes operating the data processing arrangement to employ an initialization vector (IV) in combination with the at least one key when decrypting the at least first encoded and encrypted data block and/or data packet.

20 36. A method as claimed in claim 32, characterized in that the method includes operating the data processing arrangement to decrypt and decode the encoded and encrypted data (E2) to generate the corresponding decoded data (D3) in the sequential repetitive manner by branching to a plurality of concurrent sequences of decrypting and decoding of encoded and encrypted data blocks and/or data packets using associated seed values.

25 37. A method as claimed in claim 32, characterized in that the method includes operating the data processing arrangement to decrypt and decode the encoded and encrypted data (E2) provided in a form of at least one of: encoded and encrypted one-dimensional data, encoded and encrypted multi-dimensional data, encoded and encrypted text data, encoded and encrypted binary data, encoded and encrypted sensor data, encoded and encrypted audio data, encoded and encrypted image data, encoded and encrypted video data.

30

14 07 17

38. A method as claimed in claim 32, characterized in that the method includes operating the data processing arrangement to arrange for receiving the at least one key at the decoder (120), for use in subsequent decrypting and decoding of the encoded and encrypted data (E2), manually or via an encrypted e-mail or via an encrypted communication connection.

39. A method as claimed in claim 38, characterized in that the encrypted communication connection is implemented via Secure Sockets Layer (SSL)/Transport Layer Security (TLS) protocol.

40. A method as claimed in claim 32, characterized in that the data processing arrangement is implemented by employing at least one Reduced Instruction Set Computing (RISC) processor that is operable to execute program instructions.

41. A codec (130) including at least one encoder (110) as claimed in claim 1, and at least one decoder (120) as claimed in claim 23.

42. A computer program product comprising a non-transitory computer-readable storage medium having computer-readable instructions stored thereon, the computer-readable instructions being executable by a computerized device comprising processing hardware to execute a method as claimed in claim 12 or 32.

14 07 17